

## Timbre and harmony: interpolations of timbral structures

Kaija Saariaho

*Institut de Recherche et Coordination Acoustique/Musique, Paris, France (composer)*

In this article, I discuss the use of musical timbre and harmony, and their relations, taking examples from my own works. I discuss also the use of the computer in composition and musical research. Speaking of timbre, I introduce the sound/noise axis, which I use to create musical tension and to replace the dynamic function of harmony. Along this axis, generally speaking, "noise" replaces the concept of dissonance and "sound" that of consonance. The axis is, nevertheless, only one-dimensional, and I wonder if there might be ways to organize timbre in more complex — hierarchical? — ways. In my work with the computer I seek ways of combining in a concrete way timbre and harmony, for example by using similar models for building sounds themselves and their pitch organizations.

**KEY WORDS** timbre, harmony, computer music, musical form, musical tension, musical hierarchies.

In this essay I would like to present some ideas on timbre and harmony and their relationship in musical form, ideas with which I have been able to experiment up to the present in my own work, with or without the use of the computer.

The notion I designate by the generic term "timbre" is obviously already a synthesis of several elements. Amongst these I would mention the purity of sound (including the idea pure/noisy) and its texture (grainy/smooth) which for me have a particular importance. These parameters are themselves groupings of several distinctive characteristics; the terms that I use in the context of my work are subjective and unconventional, and have actually nothing in common with the usual psychoacoustic terminology.

From my earliest compositions I was especially interested in the development of musical form: in practice this became the basis of my creative work. When I say "form" I mean precisely the idea that Vassily Kandinsky defined as the following: "Form is the external manifestation of inner meaning" (Kandinsky: *The Spiritual in Art*, 1969). Hence I have never referred to pre-established formal structures in my work. It is through an overall idea of form that I approach different musical parameters and their special problems.

In exploring the development of form I have found my attention naturally drawn to the significance of dynamism and stasis. Amongst familiar organizational models concerning pitch the tonal system is, in my own experience, the most effective means of using harmony to construct and control dynamic musical forms. This is illustrated by numerous large-scale, substantial formal structures which emerged during the age of tonal music. It would be difficult to find as dynamic a conception of form amongst other approaches. I think, however, that using tonal functions in such a way is definitely a thing of the past. This is why the tonal system would seem to me to be only a potential model for the creation of tensions through the use of pitches.

For some years now I have a tendency in my music to relate the control of timbre with the control of harmony. Initially I began to use the sound/noise axis to develop both musical phrases and larger forms, and thus to create inner tensions in the music. In an abstract and atonal sense the sound/noise axis may be substituted for the notion of consonance/dissonance. A rough, noisy texture would thus be parallel to dissonance, whilst a smooth, clear texture would correspond to consonance. It is true that noise in the purely physical sense is a form of dissonance pushed to the extreme. At the level of auditory experience, we can compare on the one hand the perception of a tension which is related by the tonic (or by a consonance if the context is not tonal) and, on the other a noisy texture which, while magnifying itself, transforms into pure sounds: one finds a certain analogy here. The "noise" in itself can actually manifest itself in different ways — soft, harsh etc. In a general way, the concept of "noise" signifies to me utterances such as breathing, the sound of a flute in a low register or a string instrument playing "sul ponticello." By contrast, a pure sound would be more akin to the ringing of a bell or a human voice singing in the Western tradition. The sound/noise axis exists as an abstraction which can be applied on different scales: it might be conveyed with a single violin bow, or by using all the instruments of an orchestra. I have also used the sound/noise concept to modulate the contour of a single instrument, as in my piece *Laconisme de l'aile* (1982) (Fig. 1). My intention here was to create an impression of polyphony on several levels for a solo instrument, to expand the melodic line in some way.

To qualify the traditional conception of timbre's and harmony's respective functions, I would say that the function of timbre is considered as being vertical and that of harmony as horizontal. Harmony therefore provides the impetus for movement, whilst timbre constitutes the matter which follows this movement. On the other hand, when timbre is used to create musical form it is precisely the timbre which takes the place of harmony as the progressive element in music.

It can also be said that these two elements become confused when timbre becomes an integral part of form and when harmony, by contrast, is confined to determining the general sonority. However, the sound/noise axis is one-dimensional. Certainly it provides poorer organizational models than a tonal hierarchy. To enrich the network of

a.s slowly  
a.s possible

PP PP legato sff tempo I ( $\text{♩} \approx 60$ )  
3 sempre legatissimo  
mp senza vibr. (sempre)  
forte possibile

The image shows a handwritten musical score for flute, consisting of three staves. The first staff begins with the instruction 'a.s slowly a.s possible' and contains notes marked 'PP' (pianissimo) and 'legato'. A dynamic marking 'sff' (sforzando) is placed above a series of notes. The tempo is marked 'tempo I (♩ ≈ 60)' and the phrasing is '3 sempre legatissimo'. A 'mp' (mezzo-piano) marking is present above a triplet of notes, with the instruction 'senza vibr. (sempre)'. Below the notes, there are several 'xxx' markings with asterisks, and the phrase 'forte possibile' is written at the bottom right of the first staff. The second and third staves continue the musical line, featuring a quintuplet (marked '5'), a trill (marked 'tr'), and a triplet (marked '3'). The second staff includes a 'p' (piano) marking and a 'd.' (diminuendo) marking. The third staff also includes a 'p' marking and a 'd.' marking. The score is annotated with various performance techniques and dynamics throughout.

(\* click any keys, not changing the written pitch; it is intended that the clicks produce a kind of vibrato)

Figure 1 Excerpt from *Laconisme de l'aile* for flute.

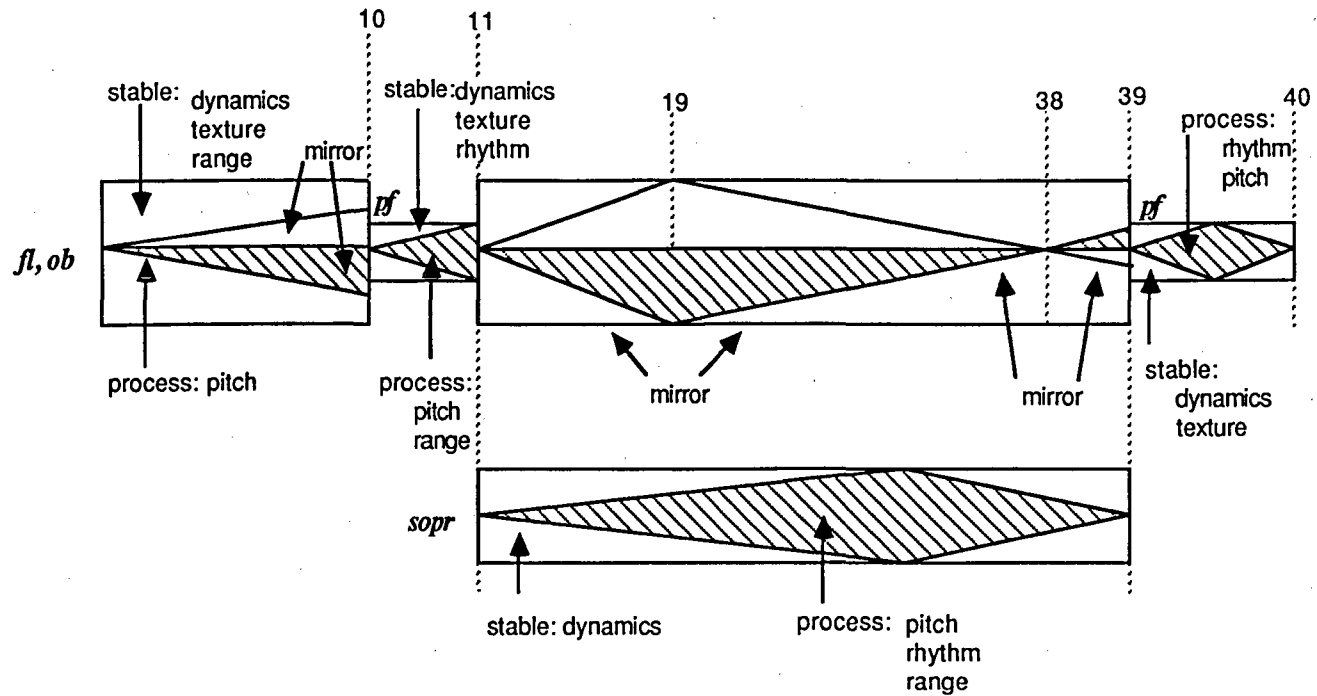

**Figure 2** Chart for the beginning of *Sah den Vögeln* for ensemble and live electronics: the processes are indicated by the wedge-shaped figures and the stable parameters by the regions above and below the wedges.

dimensions I adopted other oppositions in addition to that of "sound/noise." One can, as well, call upon timbre, but also harmony, rhythm, pitch range etc.

Of course, the construction of musical form has always used this principle of oppositions. In a composition it can be found on a small scale (JJJ) and in the larger structure of the piece (slow section/fast section); and not only in music but in all the arts. In his work *Point, Line, Plane* (1970), Kandinsky talks of fundamental oppositions in the plastic arts: the point (stasis) and the line (tension created by movement); the warmth and coolness of a color; the vertical and the horizontal. Every form of artistic creation is based on these same notions, only the terminologies differ. Ultimately, it is a question of how we perceive the world, how we distinguish one thing from another as a result of differences and oppositions.

*Sah den Vögeln* (1981, for ensemble and live electronics) is the first work in which I sought answers to the problems posed by the realization of such a multi-dimensional network. I had imagined curves of tension for each parameter — harmony, texture, dynamism, shifts of electronically-related color. The energy expressed in the work is accentuated or held back by these curves and their interaction. Each individual parameter is at times static, at times progressing from a point of extreme inertness to extreme variability. Sometimes the curves are intersected by other equivalent curves, thus creating a progression by stages within the totality of structures (Figs. 2 & 3). The processes are often almost symmetrical: after the point of culmination, each parameter returns progressively towards a new state of stability.

It is by modifying the speed of harmony's development that harmonic tensions are created, by making harmony into a strictly controlled parameter. To achieve this, I worked on the degree of differentiation of successive chords and on the linear duration of each chord.

The plastic arts have allowed me to grasp the importance of transitional spaces. Even as a child I was fascinated by the idea opened up by Goethe in his *Theory of Colors* (1810), which places the birth of colors within the confines of light and shade. The tensions created by transitional spaces fascinated me most of all as parameters with which it was possible to create musical forms. From these reflections some works resulted in which I tried to fashion a musical dynamic by using abrupt transitions between different materials and thus to compensate for the absence of large-scale tensions within the harmonic material. In these works I used widely differing textures and modes of musical performance — the only common factor between the different materials is harmony which, paradoxically, becomes the most stable element of all.

As an example, my piece *Im Traume* (1980) for cello and piano consists of harmonic material which is well-defined and non-dynamic, whilst giving a certain background color to the ensemble. This material constitutes an "area" which is modified by differing events at the level of

The musical score is divided into several systems. The first system shows the flute (fl) and oboe (ob) parts. The flute part begins with the tempo marking "calmato" and a metronome marking of  $J = 44$ . The time signature changes from  $2/4$  to  $5/4$  and back to  $2/4$ . The oboe part is marked "sempre mp". The second system continues the flute and oboe parts, with the flute marked "sempre mp" and the oboe marked "sempre mp". The time signature changes from  $3/4$  to  $2/4$ . The third system shows the flute and oboe parts, with the flute marked "sempre mp" and the oboe marked "sempre mp". The time signature changes from  $3/4$  to  $2/4$ . The fourth system shows the piano (Pf) part, with the tempo marking "attacca" and "veloce possibile". The dynamic marking is "Pf" and the tempo is "veloce possibile". The fifth system shows the piano part, with the dynamic marking "Pf" and the tempo marking "attacca".

Figure 3 The score from *Sah den Vögeln* corresponding to the chart in Figure 2.

The image displays three systems of handwritten musical notation. The first system includes staves for flute (fl), oboe (ob), and soprano (sopr). The flute and oboe parts feature complex rhythmic patterns with triplets and sixteenth notes, marked with 'tr' for trills. The soprano part has a few notes with the instruction 'sempre mp calmato'. Performance directions include 'attaca (tempo primo)' and 'Amp simile'. The second system continues the flute and oboe parts, with the soprano part starting the lyrics 'i ch bin' and the instruction 'sempre legatissimo'. The third system shows the soprano part with lyrics 'bin n e ei n ge' and continues the flute and oboe parts. The notation is dense and includes various musical symbols such as slurs, accents, and dynamic markings.

Figure 3 Cont'd.

The image displays three systems of a musical score for Soprano (Sopr), Flute (fl), and Oboe (ob). The lyrics are in German. The first system (measures 24-26) features the Soprano line with lyrics "schla-a" and "gen bin". The second system (measures 27-29) features the Soprano line with lyrics "ein-ge-schla-a" and "gen-r". The third system (measures 30-32) features the Soprano line with lyrics "un-ge-e" and "ben urrge" and "ben". The flute and oboe parts are highly rhythmic and technical, featuring many triplets and trills. The flute part includes dynamic markings like *tr* and *tr* with wavy lines. The oboe part includes dynamic markings like *AMP. SILENTE* and *AMP. SILENTE*. The score is written in treble clef with a 2/4 time signature.

Figure 3 Cont'd.

The image displays a musical score for a vocal and instrumental ensemble. The vocal part is for Soprano (Sopr.) and includes the lyrics: "n et-was ernied-ri-ge et-was ab-hä-än-gig nicht! nicht ich". The instrumental parts include Flute (fl.) and Oboe (ob.), both marked with *AMP SIMULC*. The piano part (Pf) is marked with *attaca* and *veloce possibile, ben ritmico, incolore, sempre non legata*. The score features complex rhythmic patterns, including triplets and quintuplets, and dynamic markings such as *subito disperato sfz* and *calmato mp*. The piano part is divided into four systems, each separated by a double bar line. The final system of the piano part is marked with *ritacca*.

Figure 3 Cont'd.

sff!

meno mosso  
molto espressivo,  
e amoroso!

p

p

meno mosso  
(♩ ~ 72)

sff!

8va

sff!

Loco

6

5

sf

5

pp

3

4

5

5

6

4

5

5

Figure 4 Three excerpts from *Im Traume* for cello and piano showing the types of texture.

This musical score excerpt is for piano and includes the following elements:

- Staff 1 (Piano):** Features a triplet of eighth notes marked *P* and *sf!*.
- Staff 2 (Piano):** Contains a 5/16 time signature, a *meno mosso* tempo marking, and a *dolce* dynamic marking.
- Staff 3 (Piano):** Includes a *loco* marking and a *P* dynamic marking.
- Staff 4 (Piano):** Features a 2/4 time signature, a *a tempo* marking, and a *pp* dynamic marking.
- Staff 5 (Piano):** Includes a *pizz.* marking and an *8va* marking.
- Staff 6 (Piano):** Contains a *pp* dynamic marking and a *3* triplet marking.

This musical score excerpt is for piano and includes the following elements:

- Staff 1 (Piano):** Features a *P* dynamic marking, a *sff!* dynamic marking, and a *3* triplet marking.
- Staff 2 (Piano):** Includes a *legno batt.* marking and a *P* dynamic marking.
- Staff 3 (Piano):** Contains a *tempo I* marking and a box with  $\text{♩} = \sim 60$ .
- Staff 4 (Piano):** Features a *2/4* time signature and a *mp* dynamic marking.
- Staff 5 (Piano):** Includes a *p* dynamic marking and a *5* marking.
- Staff 6 (Piano):** Contains a *sf* dynamic marking and a *8va* marking.
- Staff 7 (Piano):** Includes a *3* triplet marking and a *3* triplet marking.
- Staff 8 (Piano):** Features a *sf* dynamic marking and a *(p)* dynamic marking.

Figure 5 Excerpt from *Im Traume*.

timbre and texture. Here I tried to realize a network of textures on several levels in which "stasis" is represented by traditional instrumental techniques that form part of the harmony, whilst "extended" techniques introduce tensions. The sequences of traditional harmony, however, are divided into different textures (Fig. 4), thus making possible the adjustment of tension between "noise" and "sound," and between different textures contained within the "sound" material. Unlike the example in Figs. 2 and 3, the parameters remain intrinsically static. By contrast, the transitions from one texture to another are very abrupt (Fig. 5), as was also the case — to some extent — in *Sah den Vögeln*.

I became increasingly interested in transitory phenomena and their realization through different parameters. A system of modulation in tonal music could be the example of a dynamic musical transition creating a sense of movement. When one begins to modulate, to alter the state of stasis created by the dominant tonality and to advance towards a new, still foreign tonality, the music is then characterized by a more powerful sense of movement, which can be reinforced still more by the use of other parameters. The same model can be applied universally and is adaptable to every kind of transition in which the condition of stasis is represented by a familiar and recognizable state. In the area of speech, the minute difference between a vowel and a consonant can provide another example of this kind of transition. The idea of slowing down such a phenomenon practically to the point of complete immobility fascinated me, and I wanted to analyze it with modern technological means — I had discovered the value of a microscopic view in my own field! It was thus in my music that I began to use the amplification of instruments by microphone and other conventional analogue means as a preparation for using a computer.

My first composition realized with a computer, *Vers le Blanc* (1982), is an extreme example of the use of slowness. In this work I tried to make a tightly-knit whole by relating form and content in a radical manner. The fundamental idea of this piece is the very slow transition from one chord to another through glissandi, which are so slow that changes in pitch become imperceptible to the ear. The computer had inspired me with this idea, and it was only by this means that I could realize it. The

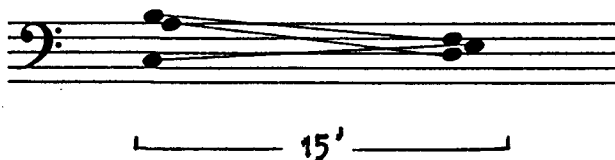

Figure 6 The "harmonic" progression of *Vers le Blanc* for tape.

glissandi last as long as the work itself (15c). Whilst spreading in different directions they produce a harmonic structure which is continuously evolving (Fig. 6). Here the harmony is impossible to perceive as a series of different chords since it is presented as a continuum, as an uninterrupted chord which is continuously modified. Only intermittently does the listener become aware that the harmony must have changed. This tends to happen when the glissandi unite to form frequency relationships or chords whose intervals are recognizable. The way in which the listener perceives the form of the work is conditioned by such moments of recognition. In memory, a form is not perceived as a continuum; rather our comprehension reduces the whole into simpler structures based on different, strongly-defined details.

Form and content are thus organically contained within the idea as a whole and become inseparable. One can, as a result, open up an entirely new path towards a primarily global musical idea by approaching form and content through the same computer technologies, which serve to realize the totality of the work.

In *Vers le Blanc* I achieved timbral transformation through two technical means: first by controlling the central frequencies of formant regions (regions of resonance) with functions of time, and secondly by creating variations of different phonemes with the help of interpolation systems.

As far as timbre is concerned, my aim in this work was to create the illusion of an endless human voice, sustained and "non-breathing," which at times departs from its physical model. This effect of differentiation is apparent when the voice is masked, reduced and distorted. This is achieved by progressively modifying the values of parameters such as the extent of aleatoric modulation on the central frequencies of formants, as well as the bandwidth of formants, the coefficients of central frequencies and the amplitude of the formants. These last two parameters modify the relationship of frequency and amplitude: thus the structure of normal formants in the human voice is altered.

With this method, the parameters just cited are controlled by time functions, which very slowly move away from ordinary values in order to return to them, equally slowly. Such symmetrical and wedge-shaped functions take turns in creating a continual variation of texture.

Working with the computer has given me ideas which are equally applicable to instrumental music. For example, the necessity of keeping all the parameters under constant control enlarged my vision of instrumental music, as did even the simple fact of noting how much one can vitalize a sound by adopting a constant micro-variation to complete its construction. In addition, the realization of transitions and interpolations through instrumental means awoke my interest.

I wanted to understand how composition could be influenced by an idea based on the notion of transition and the multi-dimensional system



Figure 7 First sketches of the global form of *Verbindungen* for orchestra and tape.

that I described above. Is a certain form given more emphasis in this way? Do certain things become completely impossible in such a framework? And what are the differences as compared with the possibilities offered by a developed hierarchical system?

In my opinion, the system I use offers the possibility of constructing forms of tension as well as structures of several levels. It is partly to prove this that I wanted to write a work making maximum use of the multi-dimensional network to create the form. This was the point of departure for *Verblendungen* (1982–84 for orchestra and tape).

The initial idea of this piece is an "impossible" overall form: a work which would begin at its highest point and whose infolding would be merely a winding down after the initial burst of energy (Fig. 7). Such a formal impossibility forced me to exploit all the parameters in as dynamic a way as possible in order to keep the music moving. For each

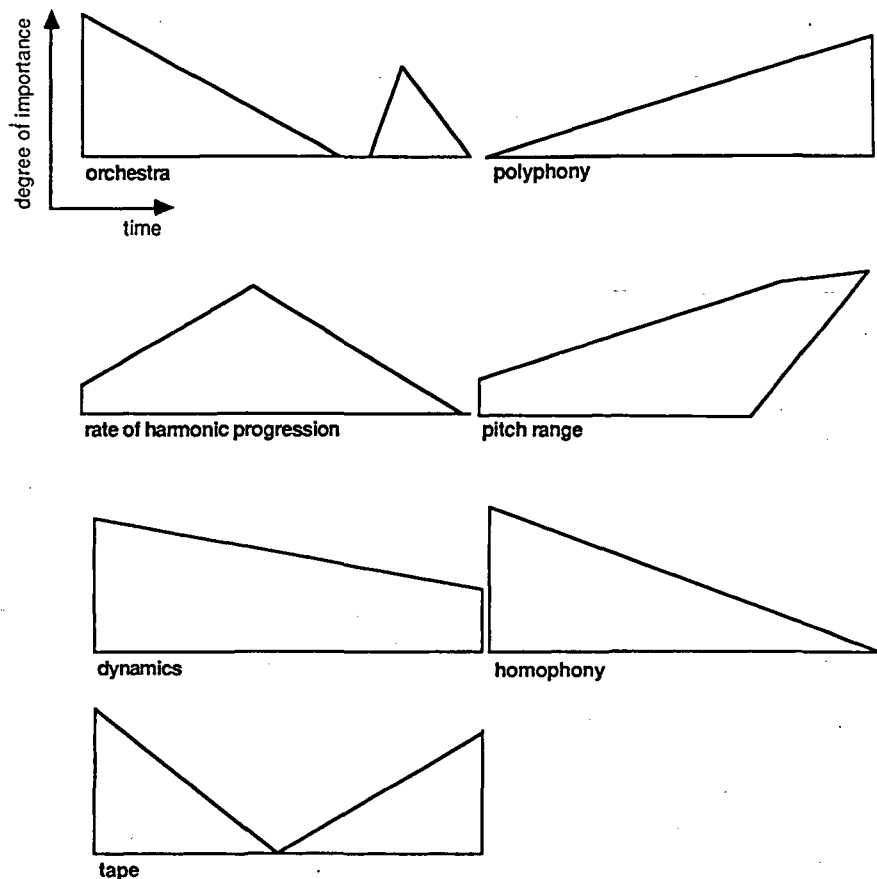

Figure 8 Curves for the evolution of the compositional parameters of *Verblendungen*. For each curve, time is represented on the vertical axis.

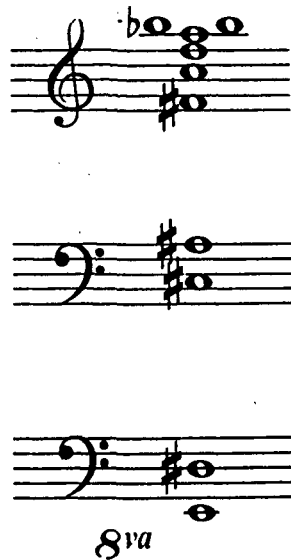

Figure 9 The basic chord of *Verblendungen*. All of the intervals are included in the chord. Some of them, like the perfect fifth and the minor third, are implied by a change in octave of one of the notes of the chord.

f	e	d
e	d	c
d	c	b
c	b	a
b	a	a
a	a	a

Figure 10 The interval a propagates itself and displaces the other intervals (b, c, etc.) towards higher pitches.

parameter I worked out a specific, evolving curve which was relative to all the others. The interaction of all the parameters constitutes the culminating points which determine the form of the work. The superimposition of "realized" curves on transparencies allowed me to conceive the whole work second by second. These evolving curves are all shaped in an identical way. Disconcertingly, they are introduced as if they had complied with the same dimensions, though each has a different significance according to how it operates at a given moment of a given parameter. For example, the "pitch range" curve immediately brings into being the evolution of the global range of the work (Fig. 8). On the other hand, the description of the tape by the curve below shows the proportional importance of the tape in relation to the orchestral part. It is thus that the graphic representation does not permit the musical

Figure 11 A concrete example of the principle of harmonic evolution in *Verblendungen*: the harmonic progression of the beginning of the piece.





Figure 12 Cont'd.

**5** **4** **3** **2**

**4** sempre furioso **3** poco meno furioso **2** sempre **3** grave







Figure 12 Cont'd.

6

2

3

4

fl  
alb sax  
ob  
cl  
cor/tra/btr  
horn I/II  
horn III/IV  
tr  
alto sax  
tbn  
tuba  
perc I  
perc II  
pf  
harp

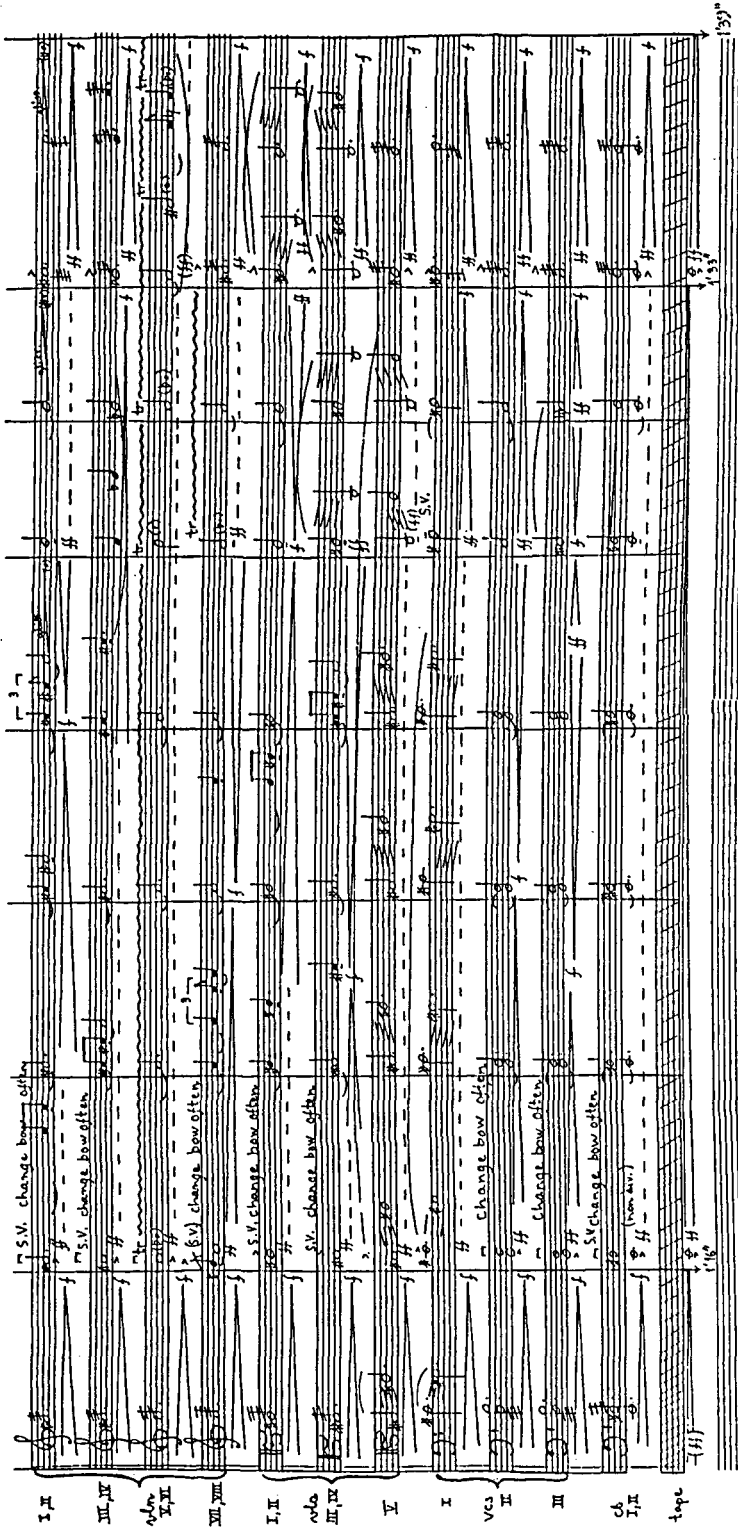

Cont'd.

Figure 12 Cont'd.

DJ 4

4

2

3

4

The musical score is organized into four measures, labeled 4, 2, 3, and 4 from left to right. The instruments and their parts are as follows:

- fl**: Flute, starting with a *f* dynamic.
- alto fl**: Alto flute, starting with a *f* dynamic.
- sb**: Soprano saxophone, starting with a *sf* dynamic.
- cl**: Clarinet, starting with a *sf* dynamic.
- cor**: Cor Anglais, starting with a *f* dynamic.
- horn I, II**: Horns, starting with a *f* dynamic.
- horn III, IV**: Horns, starting with a *f* dynamic.
- tr**: Trumpet, starting with a *f* dynamic.
- alto sax**: Alto saxophone, starting with a *f* dynamic.
- trb**: Trombone, starting with a *f* dynamic.
- tuba**: Tuba, starting with a *f* dynamic.
- perc I**: Percussion I, starting with a *f* dynamic.
- perc II**: Percussion II, starting with a *f* dynamic.
- pf**: Piano, starting with a *f* dynamic.
- harp**: Harp, starting with a *f* dynamic.

Additional performance instructions include "change to xylophone" for the percussion part and "Bb Ct" for the harp part. The score uses various dynamic markings such as *f*, *sf*, *mf*, and *ff*, and includes trills and other musical notations.





This is a handwritten musical score for a string ensemble, consisting of 21 staves. The notation includes various rhythmic values, dynamics (e.g., *ff*, *f*, *rit.*), and performance instructions such as *poco a poco S.P.* (poco a poco sostenuto) and *rit.* (ritardando). The score is divided into sections labeled with Roman numerals I through XIII, and includes a section for Cb (Cello) and a final section for Bass. The notation is dense, with many notes and rests, and includes some specific markings like *dis.* (dissonance) and *memoranda*.

3.11 change bar often but non-asser, very each

significance to be deduced, but it serves as a memory aid to the form of each parameter, preventing me from losing sight of the work as a whole.

The principle elements in this piece are timbre and harmony. I will now try to clarify the reciprocal relationships between these two parameters in the work. With timbre, the overall development is clear: the tape part begins with noisy, rhythmical material and ends with a quasi-orchestral luminosity made up of violin sounds. Conversely, the overall development of the orchestral part is the opposite of this: instrumental sounds take on a more and more noisy texture until they are completely lost in the quasi-orchestra of the magnetic tape.

To counterpoint this extremely clear evolution with its very obvious profile, I wanted to find a solution for the harmony that was multifaceted and which would allow me to discover a new way of approaching harmony, a way which would allow me to develop the form. I therefore approached the question of harmony as follows: I constructed a fundamental chord containing all the intervals (Fig. 9). From this chord the harmony radiates in different directions in such a way that each time a different interval from the fundamental chord ends up occupying the totality of the vertical structure (Fig. 10). Once arrived at this conclusion, i.e. when the chord consists of only one interval, the harmony again disintegrates to return to the fundamental chord. In this system, a chord which is familiar somehow assumes the function of consonance.

From the harmonic point of view, however, the result is surprisingly homogeneous. The different structures are not perceived separately, at least not in an awkward way. Three factors helped to bring this about. The first is the fold-over of the chords: the range of pitches in the work is really a very precisely determined parameter, as previously shown. At the beginning it occupies a restricted area and proceeds to grow throughout the duration of the piece. Initially the notes which threaten to exceed the given limits are retrieved by fold-overs (Fig. 13).

The second factor is the speed of the harmonic progression, which is very slow at the beginning since the transition from one chord to another occurs via a note-by-note progression, whilst further on changes occur without such an intermediary stage. This rate of progression was also minutely calculated, and before beginning the work of composition proper I devised a map for the overall harmonic structure of the work comprising the exact duration of each sequence (cf. the progression in Fig. 11 and its partial realization in the score of Fig. 12).

The third factor which effectively limited the heterogeneous qualities of the harmony in a decisive way was, finally, my ear. It is that which ultimately determines the existence of each chord, thus making the totality more homogeneous. With the ear I always found a means of remodelling an uninteresting chord, often without even breaking the rules that I had fixed for myself.

Overall, my initial solution for the harmony functioned as I had wished it to; the chords regenerated themselves continuously and I was

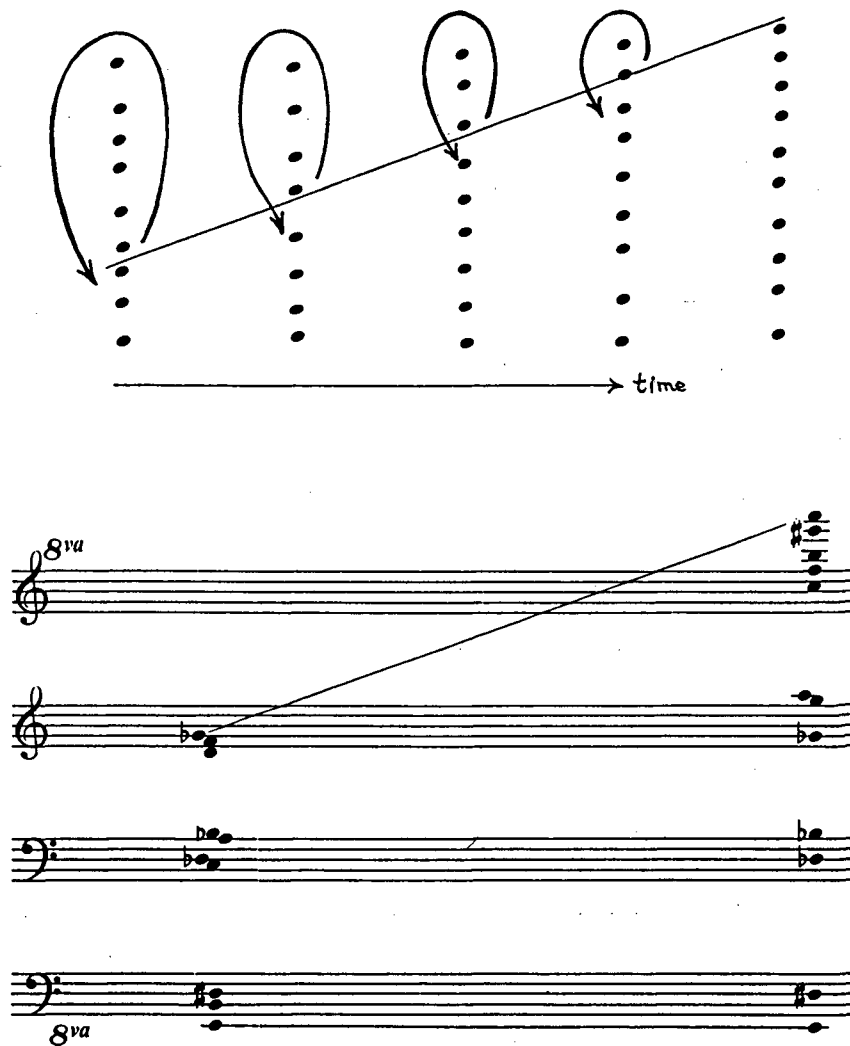

Figure 13 a) The "fold-over" procedure for pitches that exceed the given range.  
 b) The pitch range defined by the harmonic progression.

nonetheless able to use them in a dynamic way.

In all the cases that I have just described, I worked on the timbre and harmony by considering them as separate parameters which had frequent points of contact. After my first experience with the computer I was increasingly interested in the combined possibilities of these two parameters, as well as being fascinated by the overall possibilities offered by the computer as regards the organization of musical structures. I had also been attracted to the possibility of erasing the division between organization and organized material — something which would be equivalent to effecting the fusion of timbre and harmony. I therefore began to develop a system of programs which would make the realization of such ideas possible, and allow me to combine ideas about musical interpolations and different changes of texture already described.

Before explaining in detail my work related to timbre, I might add a word on the programs that I use. In fact, all the parameters are controlled, more or less, with the same starting point. The basic idea of my programs was to construct a common framework for all the musical parameters, in which they could be controlled according to different processes and interpolations. My objective was thus to make the computer and composition better integrated, and to find new solutions in the field of compositional technique (Saariaho, 1985).

My programs were realized with the compositional assistance language FORMES coupled with a version of the CHANT program for sound synthesis and processing developed at IRCAM (Rodet & Cointe, 1984; Rodet, Potard & Barrière, 1984). Generally the programs were made up of patterns whose values are fixed by lists of values for each chosen parameter. The lists of values are then regrouped. In addition to these matrices, i.e. the lists and groups of lists, one can use several time functions to determine the general evolution. On one matrix the values are attributed to a number of desired elements and the interpolation ratios can be determined. Within the sound an interpolation can be realized either between two values or within a circular matrix in which each value is modified before being reproduced, which continually modifies the general character of the pattern (Fig. 14).

Such a circular matrix can be presented, for example, in the form of a chord in which each note is moved during the process towards the note of a new chord. My aim is to create a multi-dimensional network in which detail is strictly controlled on several levels. A process which modifies itself permanently can be realized, for example, by combining the lists of different parameters, consisting of matrices of different dimensions for each parameter (Fig. 15).

I used this system of programs for the first time in a study entitled *Jardin Secret* (1984–85). In this piece harmony and timbre have, in part, the same starting point. In fact, some intervallic structures are the same for the two elements. These structures have as their basic principle a division of the octave in different symmetrical steps. I chose to use symmetrical scales to create a new, contradictory world. For harmony

a) simple interpolation

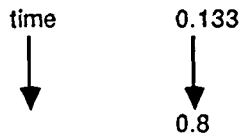

b) circular list

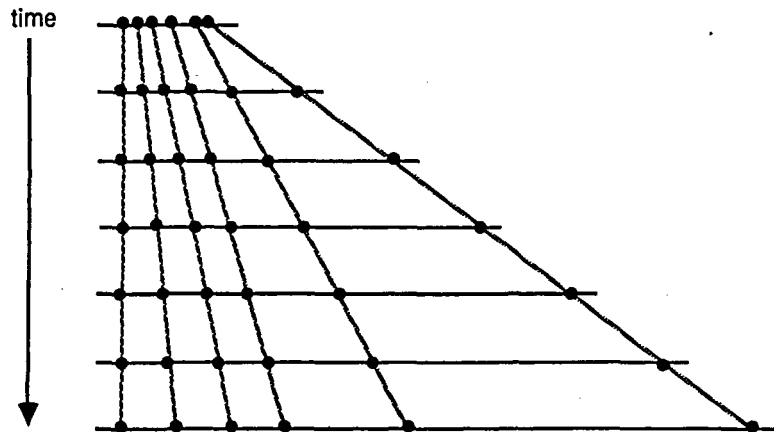
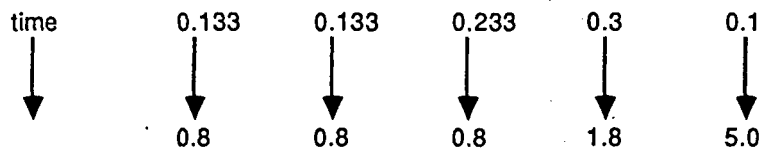

Figure 14 Types of interpolation: a) simple interpolation between two values; b) interpolation between 2 circular lists of values. Without interpolation no change will take place in the list of values. With interpolation each value will change gradually in the direction of its target value.

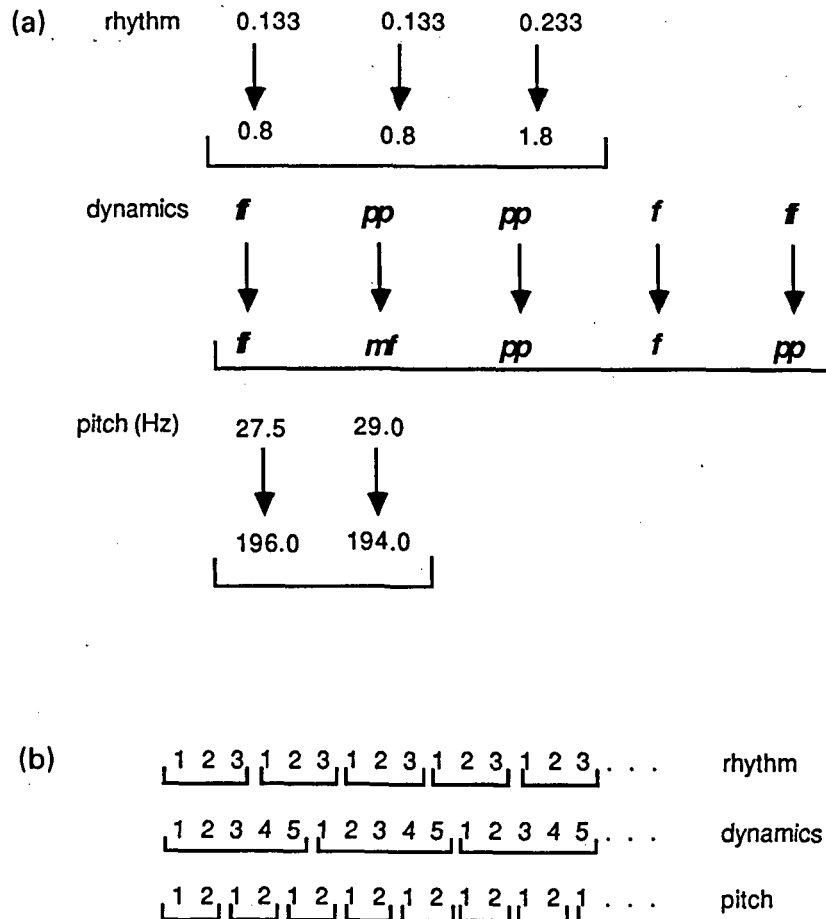

Figure 15 a) Pairs of circular lists for rhythm, dynamics and pitch. b) Since the number of elements of each list are not the same, the cycles of change in the various parameters are not synchronized among themselves.

they are used first of all in such a way that the initial chord is modified by an interpolation to produce the next chord. The harmony is thus divided into more stable or more dynamic segments according to whether one moves from one system of intonation to another or stays in the same system. The inner movement of sounds is initially minimal, the sounds remaining coherent, intact and clear. In the first half of the piece the timbre itself follows an evolution which is largely its own, from clear, abstract sounds to sounds which are increasingly noisy and voiced. Here I used the identity or the referential capacity of the sounds as a means of providing a formal punctuation.

Then, as the piece approaches its close, the same intervallic structures are used to construct sounds with an extreme reduction in the bandwidth of formants; the bandwidth is reduced almost to nothing and, as a result, gives an inharmonic sound (with almost pure sounds at the central frequencies of the formants). These sounds in themselves form departure chords for different processes which are realized by the matrices. As an example I would take the last three minutes of the piece, in which only material from inharmonic sounds is used. In this material the timbre and the harmonic structures are therefore controlled by means of the same points of departure.

The chords are stored in a memory from which they can be extracted when desired in order to construct a series of chords. One then proceeds by making a list to align the chosen chords and to determine the duration of each chord and each transition between two chords (Fig. 16). If desired, one transition can last a very long time, to the point where — in an extreme case — it attains a length equal to the duration of the two adjacent sounds. Equally, it can be much shorter, as in the present example. The harmony's progression thus consists of its own durational ratios which are independent of the rest. At this stage many successive sounds share the same timbre, taking account of the differences in the

chords	duration (sec)	duration of transition
a	5.	0.7
b	3.	0.6
c	3.	0.4
d	2.	0.3
e	4.	0.2
f	3.	0.5
g	2.5	0.5

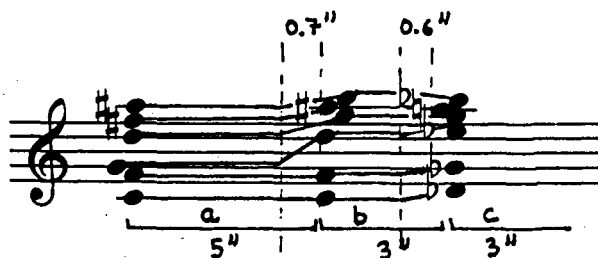

**Figure 16** a) The sequence of durations of the chords and the durations of the transitions between them. b) Realization of this sequence for chords a, b and c.

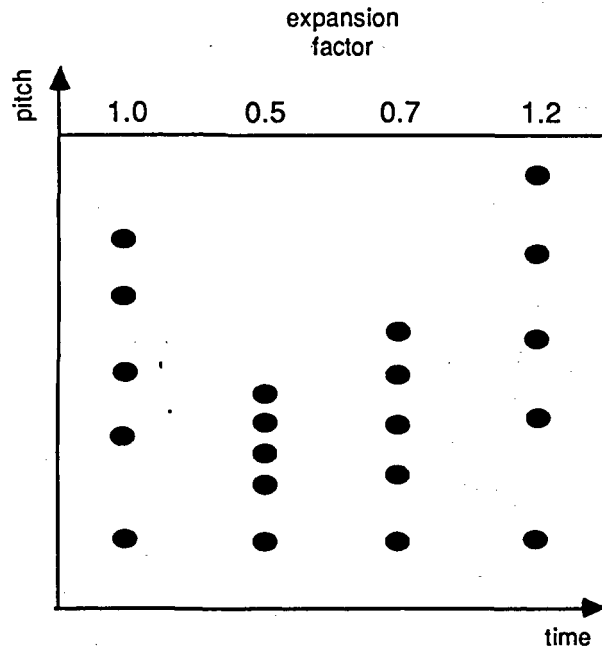

**Figure 17** The evolution of a chord by the application of a series of expansion factors.

chord progression and in rhythmic durations. This is why I wanted to relate another process to the chord progression which modifies the timbre each time a note is changed and also causes harmonic variations by distancing the harmony from its points of departure. I realized this process by applying what I call an expansion matrix, which allows one to modify the spectral envelope by contraction or expansion of formant frequencies, whilst leaving intact the internal relationships of these frequencies (Barrière, 1984). The expansion matrix is a circular list which makes it possible to fix a specific process for each desired element; the latter in turn shape the chords which follow (Fig. 17).

This is an example of a process which could not be realized without the computer. Whilst the instrument itself and the use one makes of it are controlled by the same principle, the situation for the composer becomes fundamentally different from that of the classical approach based on traditional instruments. For the composer these new possibilities signify a new aesthetic, access to an overall concept from the stage of planning form and materials up to the final perfecting of its result in sound, by passing through the general organization of the work.

In a sense, this is a completely logical progression in the evolution of Western music. In fact, from the beginning of the century composers have tried to control increasingly numerous independent parameters



Figure 18 Transitions between pure and noisy sounds: a) by increasing the pressure and moving the bow toward the fingerboard; b) by playing a glissando from one harmonic to another.

whilst looking elsewhere for organizational modes common to these different parameters. In addition, new computerized methods of analyzing sound lead us to many openings. All this recently acquired knowledge enriches the work of the composer. For example, the identical structures of the detail and of the whole that I described earlier when talking of *Jardin Secret I* are, typically, the solutions that computer science has made possible today, but which would have been unthinkable in the past.

My piece *Lichtbogen* (1985–86, for ensemble and live-electronics) could be an example of the use of computer analysis techniques in the area of instrumental music. The harmonic material used has been derived from the sounds of a cello analyzed with the use of a computer. Here I was particularly interested in the rich and noisy sounds of the cello obtained by increasing the pressure of the bow to produce a multiphonic sound. The transitions between such sounds also attracted my attention. As points of departure I chose two types of transition in which the sound is transformed as gradually as possible from one pure sound — here a string harmonic (natural or artificial) — to a very noisy sound. Here it is either a question of increasing the force of the bow whilst approaching the fingerboard (Fig. 18a) or of sliding from one harmonic to another (Fig. 18b). These transitions are then analyzed by taking samples from

different phases in the sound. The data thus obtained served to construct harmonic progressions. The transitions which here are the basis of the harmony again arise from an application of the sound/noise axis. This time the string harmonics correspond to the "consonance" end of this axis, whereas "dissonance" is represented by noisy sounds broken up into multiphonics. Here the areas of timbre and harmony coalesce in so far as different kinds of playing are associated with the harmony. It is thus that a chord "under tension" can be played with an over-pressure of the bow, like the sound originally analyzed which had served to produce the chord in question.

The conception of overall form can also draw its inspiration from microphenomena. I see above all the possibility of a common creative thought implying the ensemble of different levels, aiming to create, for example, structures composed of different interlocking symmetrical forms.

With respect to this I should emphasize that all this need not mean that computer-oriented composition is a less visionary activity than orthodox work with pencil and paper. Speaking of my own work, I mentioned previously on the one hand the generative idea from which I progress towards detail, and on the other hand the shaping of the sound and its microstructures which can set the entire thing in motion. I tend to think it is a question of one and the same thing: my creative process has not reversed itself, but I am approaching the same thing in a different way. It is a question of an intuitive experience, an overall vision which is the catalyst for a piece of research and the actual realization of musical materials. All this had its place in the process which serves to create a work; all these factors maintain very complex and diverse interactions. In addition I have been able to modify my way of thinking through contact with the computer. I find it difficult to be aware of these changes. Each composition is for me the result of the preceding one, not forcedly logical but the only one possible. Whether one works with or without the computer, the numerous elements in the creative process — most, let's say — will always escape the conscious observation that the composer can bring to bear on herself.

I have spoken a great deal about the use of computers. I actually believe that it occupies a key position in the evolution of contemporary musical thought. In relation to traditional instruments (and to the physical and human constraints that determine their use), the computer offers limitless possibilities. In other respects, these possibilities are still very limited. However, in spite of its limitations, computers offer the composer a starting point which is clearly more revolutionary than present day instrumental music. The computer makes it possible — and one cannot escape from this — to look anew at the received ideas of instrumental music. I believe, however, that the richest creative possibilities are at present to be found in the combination of computer resources and acoustic instruments: one thus comes fully to exploit their respective advantages and to compensate for their deficiencies.

Through work in progress I am trying to extend my research along the

lines that I have just described. My aim is to clarify the image of the sounds and to highlight the profile of the functions on which I am working, so that the different systems of intonation or scales can be really perceived and felt. When it comes to associating timbre and harmony, however, research of a purely physical nature is indispensable: when one works with the components of sound itself it is often very difficult to predict the final results. By seeking common or differentiating characteristics in timbre and harmony, one risks becoming enmeshed in a multitude of parameters whose many relationships seem impossible to determine.

I am currently engaged in a research project with Stephen McAdams the aim of which is to delineate certain boundaries relating to timbre and harmony and to approach the use of timbre in place of harmony. One of our keenest objectives is the search for a model for an organizational hierarchy of timbre. I would also mention a model of ambiguity akin to that constituted by modulation in tonal music: how can a chord or a pitch suddenly assume a new function and thus give rise to utterly different relationships amongst the same, previously known factors? Do similar modes of organization exist for timbre, or do our ears (or minds) work differently according to whether they register timbre or pitch? (For example, with timbre, associations could interfere to a much greater extent than they do for pitch . . .) Can timbre, like tonal harmony, serve to construct similar tensions on several levels, or would it be in spite of everything a secondary parameter in relation to rhythm and tonality, as has often been supposed? We have already obtained some answers in a study devoted to the behavior of phonemes and non-harmonic sounds according to the variations of different parameters (McAdams and Saariaho, 1985). I described such musical applications earlier when speaking of my piece *Jardin Secret I*. Figuring prominently among our conclusions was the necessity to master the complexity of the problem. To discover rules which are generally applicable one must have high quality equipment functioning in real time which allows one to modify the parameters simultaneously and to hear the result — something which ultimately facilitates the testing of the musical function of the ideas.

The above could be an example of the fusion of art and technology in our age. Contrary to what one might imagine, I find that the progress of technology liberates creativity and extends the imagination. At least, I hope this art, coming from the advent of the computer age, this cold, technocratic art, unable to avoid the use of the machine (since it is devoid of the appropriate capabilities) will be superseded by a new form of sensibility and flexibility, as technology becomes increasingly subtle and varied.

Musically speaking, I would wish to realize two kinds of projects in the near future: compositions based on the association of computer science and acoustic instruments and studies perhaps in a more reduced format, entirely realized with the computer. These two areas each have their own conditions when one attempts the fusion of timbre and

harmony. In the acoustic/computer field I am looking primarily for the use of different means of agreement. As for purely electronic music, I would wish to pursue above all my research on the boundaries of harmony and timbre, as I have just described, and also to advance towards the discovery and creative use of eventual hierarchies of timbre.

Of course, to set out on a course of research on hierarchical models in tonal music can — and must, even — be thought of as questionable. Personally, I am bothered by having to mention the subject of tonal harmony so many times in the course of this article, since from another point of view I am absolutely convinced that this is an out-dated approach to the problems posed by the organization of pitch structures. In self-defence I would say that I know no other equally effective means of creating dynamic forms; but then is it really *necessary* to create dynamic forms? In our ideal conceptions of forms, in our way of perceiving reality, what is the role of cultural conditioning and what is the role of the innate? What is eternally and universally human? In an age where man explores outer space, is it still reasonable to apply a principle dating from Newtonian times whilst using entirely new means? Shouldn't one discover totally new principles for musical form, for example, which would reflect our time?

Personally, I believe that a certain part of our approach to the world is effectively innate. Amongst fundamental factors is, notably, the principle of approaching and analyzing things and forms by way of differences. To apprehend reality we cannot abandon the principle of opposition. (I will not venture into a consideration here of the exciting domain of ritual, monotonous and hypnotic musics, of minimalism, and their possible points of comparison in relation to ideal Western form).

The mechanical repetition of archaic forms is in itself only a non-creative non-art. But just as the universe of Newton is contained within the universe of Einstein, contemporary music can similarly contain, in addition to other elements, all the developed knowledge of our civilization, as well as the knowledge that we have been able to acquire about other civilizations. Our knowledge never ceases to grow, as much of the microcosm as of the macrocosm. Such knowledge continually alters our way of thinking, of feeling and conveying our experience. A new flexibility of movement between disciplines characterizes our age as much in the arts as in the sciences. In my dreams of the future, dimensional axes, microscopes, telescopes, videos and lasers cross-fertilize and provide the material — hardly coherent as yet — that will enlarge my dimensional network.

Translated by S. Welbourn

## References

- J.B. Barrière, "Chrède 1: The pathway to new music with the computer." In T. Machover (ed.) "Musical Thought at IRCAM," *Contemporary Music Review* 1 (1) 181-202 (1984).
- J.W. von Goethe, *Theory of Colours* (1810).
- W. Kandinsky, *Du spirituel dans l'art* (Denoël, Paris, 1969).
- W. Kandinsky, *Point-Ligne-Plan*, in *Ecrits Complets: La Forme* (Denoël, Paris, 1970).
- S. McAdams & K. Saariaho, "Qualities and functions of musical timbre, *Proceedings of the 1985 International Computer Music Conference, Vancouver* (Computer Music Association, Berkeley, 367-374, 1985).
- X. Rodet & P. Cointe, "FORMES: Composition and scheduling of processes." *Computer Music Journal*, 8 (3) 32-50 (1984).
- X. Rodet, Y. Potard & J.-B. Barrière, "The CHANT project: From synthesis of the singing voice to synthesis in general." *Computer Music Journal*, 8 (3) 15-31 (1984).
- K. Saariaho, *Im Traume* for cello and piano (Jasemusiikki, Hämeenlinna, Finland, 1980).
- K. Saariaho, *Sah den Vögeln* for ensemble and live electronics (Finnish Music Information Center, Helsinki, 1981).
- K. Saariaho, *Laconisme de l'aile* for flute (Jasemusiikki, Hämeenlinna, Finland, 1982).
- K. Saariaho, *Vers le Blanc* for tape (IRCAM, Paris, 1982).
- K. Saariaho, *Verblendungen* for orchestra and tape (Edition Wilhelm Hansen, Copenhagen, 1982-84).
- K. Saariaho, *Jardin Secret I* for tape (IRCAM, Paris, 1984-85).
- K. Saariaho, "Shaping a compositional network with computer." *Proceedings of the 1984 International Computer Music Conference, Paris* (Computer Music Association, Berkeley, 163-166, 1985).
- K. Saariaho, *Lichtbogen* for ensemble and live electronics (Edition Wilhelm Hansen, Copenhagen, 1985-86).